

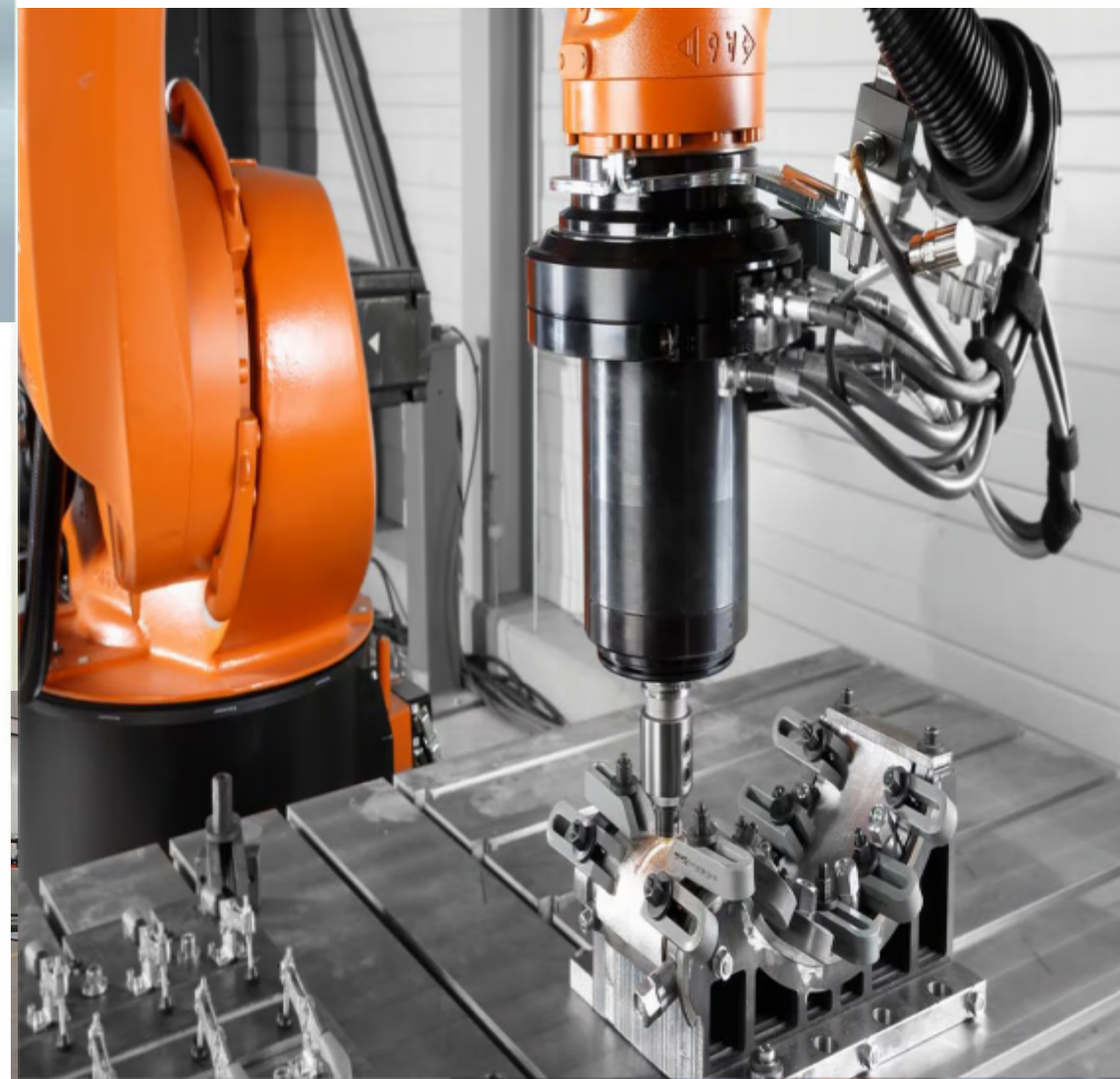

China Loong Metal Machine Co., Ltd

Website : china-metalmachine.com



INTRODUCTION

China Loong Metal Machine Co., Ltd are the Professional manufacturer and exporter who are concerned with more than 15 Years of experience for design, development and manufacture of cold roll forming machines, roofing system accessories, and hardware products. And have a professional technical team, which can customize design and manufacture the roll forming machines to meet the requirements of different processes, so as to meet the personalized needs of customers. Such as standing seam roofing machine, automatic smooth/ crimping roofing curving machine, C/ Z/ U-shape purlin machine, light steel framing machine, step tile roofing machine, wall/cladding forming machine, PU/PIR sandwich panel foaming line, floor decking machine, leveling-slitting-cutting machine, gutter roll forming machine, rib roofing machine with flying cutting & high speed 60m/min, pipe roll forming machine, Al clip, steel clip, solar bracket, shear studs and other related products for roofing system.

As the High-Tech Enterprise, We have successfully got 15 items of National Technology Patents and some CE Certificates for our roll forming machines. All of our products comply with international quality standards and are greatly appreciated in a variety of different markets throughout the world. Such as Korea, Philippines, Malaysia, Brunei, Singapore, Indonesia, Thailand, Vietnam, India, Turkey, Sri Lanka, Pakistan, UAE, America, Uganda, Canada, Brazil, Bolivia, Australia, etc. over 30 countries.

If you are interested in any of our products or would like to discuss a customized order, please feel free to contact us. We are looking forward to forming successful business relationships with new clients around the world in the near future.

We are always ready for you !

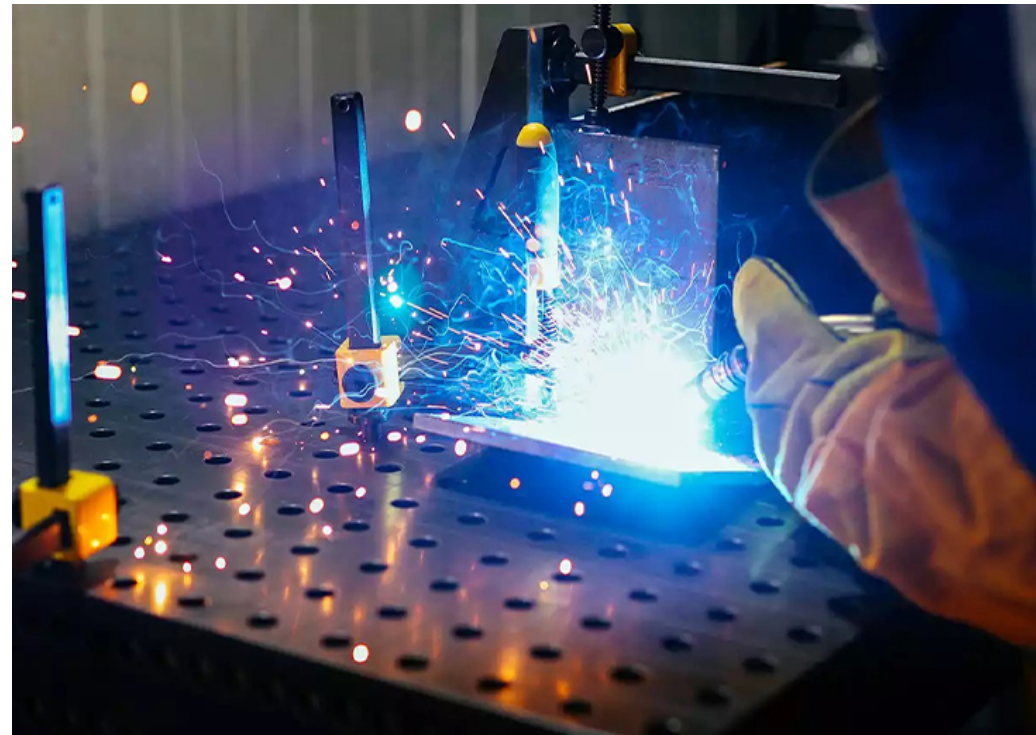

CONTENTS

Straight & Tapered Standing Seam Roofing Machine	1
Profile Drawing for YX65*300/400/425/500 Standing Seam	2
Standing Seam Roofing Machine with Automatic Changed Sizes	3
Automatic Smooth Curving Machine for Standing Seam	4
1"/1.5"Portable Standing Seam Roofing Machine	5
Smooth Curving Machine for 1"/1.5" Standing Seam Roofing	6
Automatic Tapered Sheet Slitting Machine	7
Portable Leveling Slitting Cutting Machine	8
Rib Roofing Crimping Curving Machine with Turning Direction	9
Crimping Curving Machine for Standing Seam Roofing	10
Seamlock Roofing Roll Forming Machine	11
Boltless Seaming Roofing Roll Forming Machine	12
Trapezoid Rib Roofing Roll Forming Machine	13
Rib Roofing Roll Forming Machine with Hydraulic Motor Driving	14
Trapezoid Rib Roofing Roll Forming Machine	15
Rib Roofing Machine with Laminating EPE Insulation	16
Double Layer Rib Roofing Roll Forming Machine	17
Double Layer Roofing Roll Forming Machine	18
Corrugated Roofing Machine with Flying Cutting & High Speed 60m/min	19
Automatic Stacker for Roofing Panel	20
Shape Shearing Tile Roofing Roll Forming Machine	21
Antique Glaed Tile Roof Roll Forming Machine	22
Step Tile Roofing Machine with Automatic Adjusted Thickness Gap	23
Locking Lapping Roofing Roll Forming Machine	24

CONTENTS

Ridge Cap Roll Forming Machine	25
Eave Gutter Roll Forming Machine with Automatic Changed Sizes	26
Siding/Cladding Panel Roll Forming Machine	27
Cladding/Wall Panel Roll Forming Machine	28
Metal Ceiling Forming Machine with Automatic Changed Size	29
Fascia Board Roll Forming Machine	30
Continuous PU/PIR Roofing Sandwich Foaming Line	31
Sandwich Bottom Panel Roll Forming Machine	32
M Profile Bottom Board Roll Forming Machine	33
Structural Liner Tray Roll Forming Machine	34
Flat Decking Forming Machine with Automatic Changed Sizes	35
Web Metal Floor Decking Roll Forming Machine	36
Downspout Forming Machine with Curving & Decreasing 3 in 1	37
Downpipe Forming Machine with Curving & Decreasing 3 in 1	38
Square Pipe Roll Forming Machine	39
Hat Shape Purlin Forming Machine with Automatic Changed Sizes	40
Unistruct/C Channel Roll Forming Machine For SS316	41
Automatic Adjusted C/U Profile Machine with Flying Cutting & High Speed 60m/min	42
C Purlin Roll Forming Machine with Automatic Changed Sizes	43
Z Automatic Adjusted Purlin Roll Forming Machine	44
Automatic C & Z Interchangeable Purlin Machine	45
Automatic Stacker for C Purlin Machine	46
Uncoiler	47
Seaming Machine	48

Straight & Tapered Standing Seam Roofing Machine

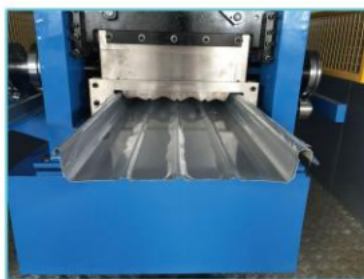

Profile Drawing for YX65*300/400/425/500 Standing Seam

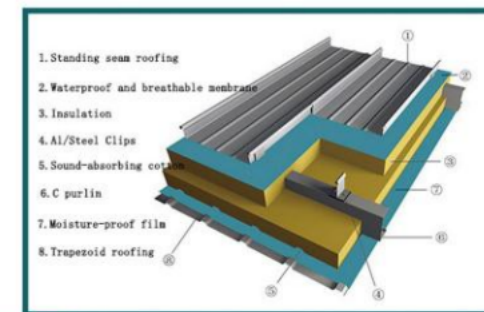
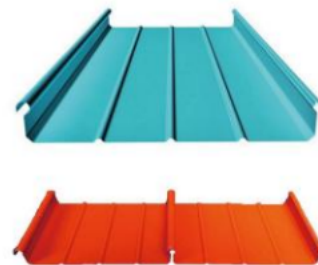
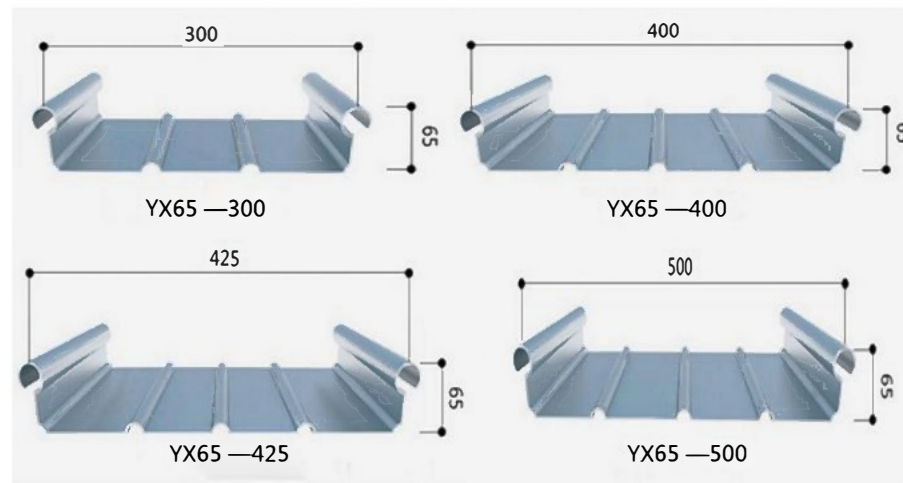

Main Technical Parameter	
Type	YX65-300/400/425/500
Material Width	475/575/600/675mm
Effective Width	300/400/425/500mm
Material Thickness	Steel:0.5-1.0mm、Al:0.7-1.2mm

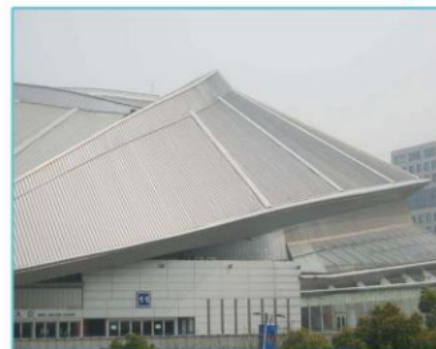

Standing Seam Roofing Machine with Automatic Changed Sizes

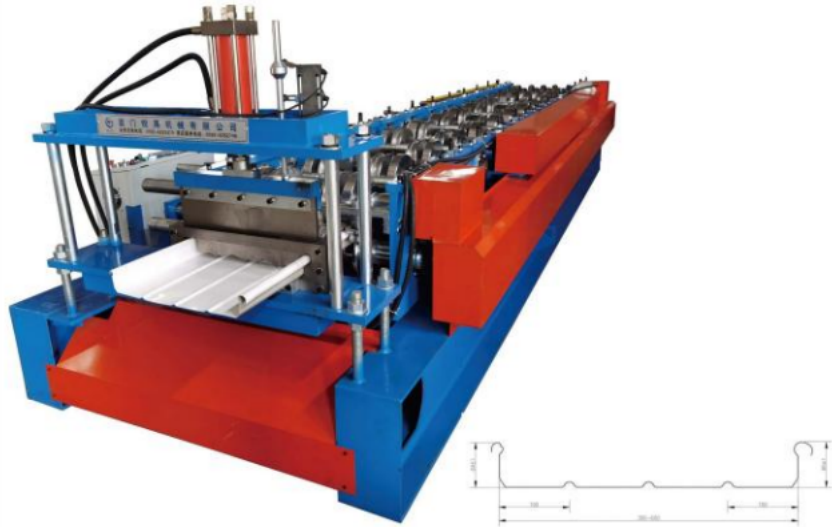

Main Technical Parameter	
Type	YX65-300-600
Material Width	475-775mm
Effective Width	300-600mm
Material Thickness	Al:0.7-1.2mm、Steel:0.5-1.0mm

Automatic Smooth Curving Machine for Standing Seam

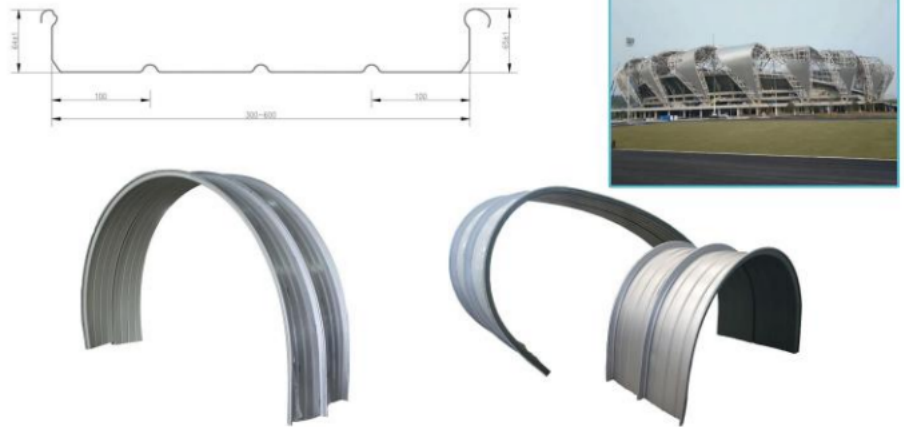

Main Technical Parameter	
Type	YX65×300-600
Min. Convex Curved R	Al:1m、 Steel:4m
Min. Cancave Curved R	Al:6m、 Steel:8m
Roofing Thickness	Al:0.8-1.2mm. Steel 0.7-1.0mm

1"/1.5" Portable Standing Seam Roofing Machine

Smooth Curving Machine for 1"/1.5" Standing Seam Roofing



Main Technical Parameter	
Type	KLS25/38×220-530
Material Width	290/600mm
Effective Width	220/530mm
Material Thickness	Al:0.7-1.0mm、Steel:0.5-0.8mm

Main Technical Parameter	
Type	KLS25/38×220-530
Min.Curved R	Convex:1m,3m、Concave:4m,6m
Roofing Width	220-530mm
Roofing Thickness	Al:0.8-1.0mm、Steel:0.7-0.8mm

Automatic Tapered Sheet Slitting Machine

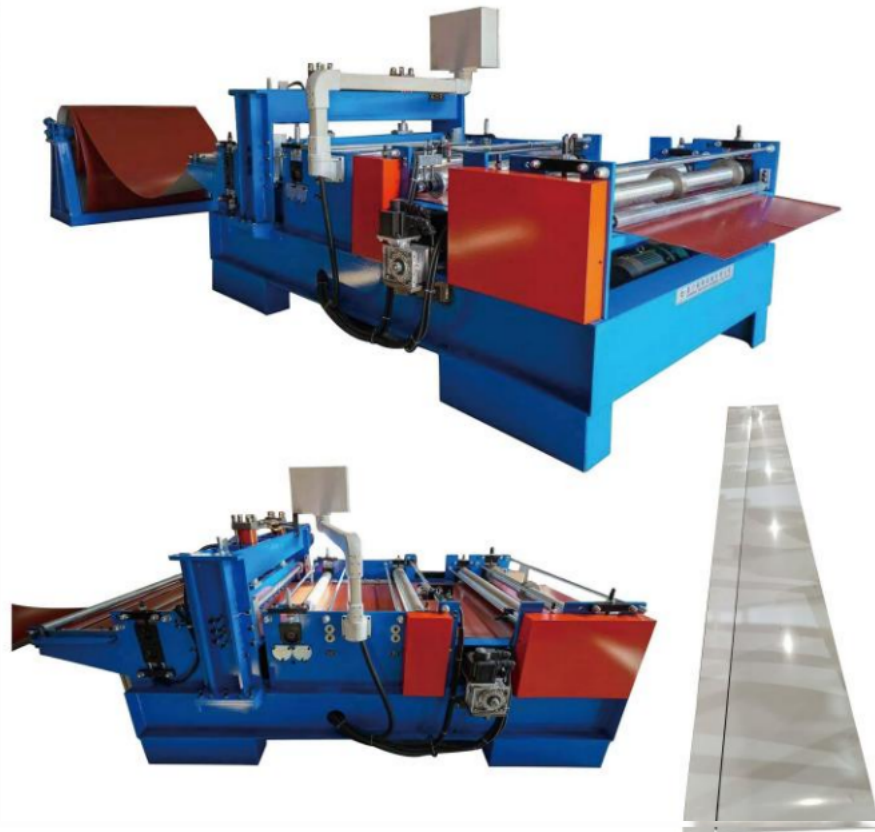

Main Technical Parameter	
Type	ST0.5-1.2-1250
Material Width	1250mm
Slitting Taper Ratio	1:30
Material Thickness	Al:0.7-1.2mm、Steel:0.5-0.8mm

Portable Leveling Slitting Cutting Machine



Main Technical Parameter	
Type	ST0.3-2.0-1300
Material Width	1300mm
Max Slitting QTY	6pcs/time for T. 0.3-0.6mm
Material Thickness	Cut 0.3-2.0mm, Slit: 0.3-1.0mm

Rib Roofing Crimping Curving Machine with Turning Direction

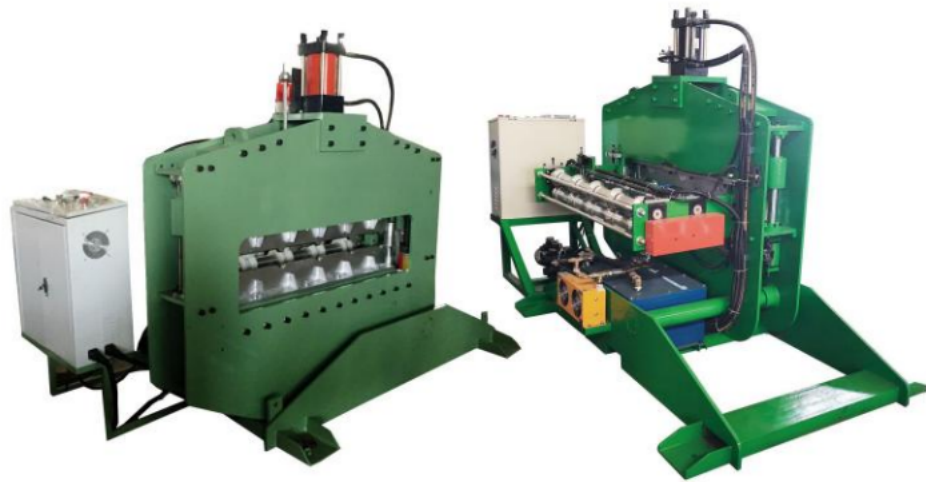

Main Technical Parameter	
Type	YX22-1070
Roofing Width	1070mm
Min. Curved Radius	Convex R. 0.4m
Roofing Thickness	0.4-0.8mm

Crimping Curving Machine for Standing Seam Roofing

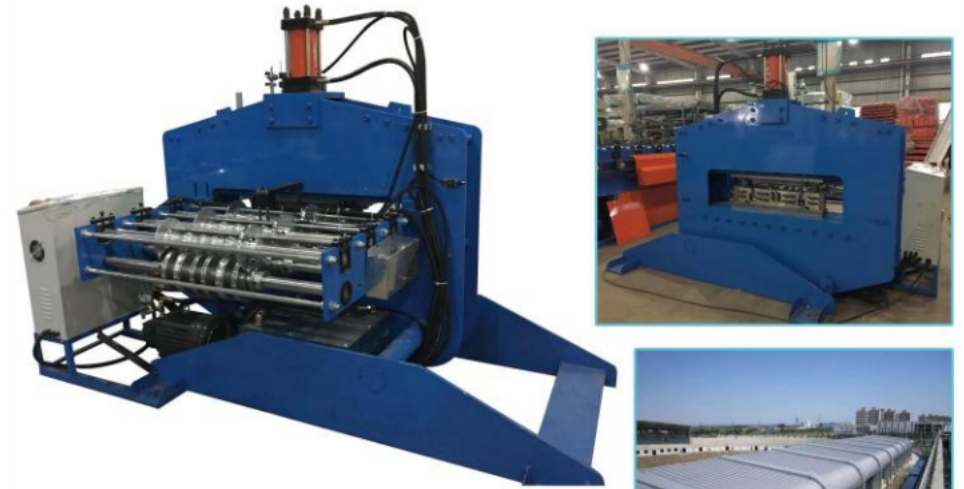

Main Technical Parameter	
Type	YX65-300-400-425-500
Roofing Width	300mm,400mm,425mm,500mm
Min. Curved Radius	Convex R. 1m
Material Thickness	Al: 0.7-1.2mm, Steel: 0.6-1.0mm



Seamlock Roofing Roll Forming Machine

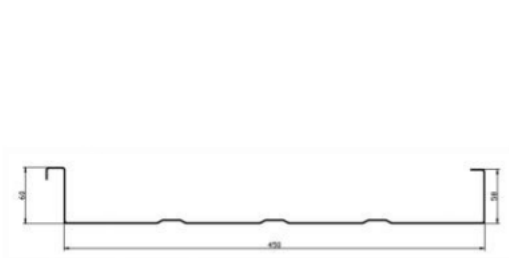
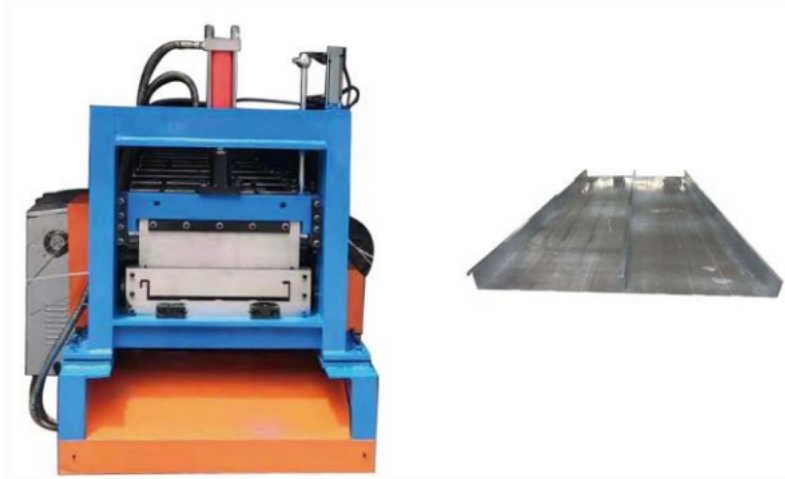

Main Technical Parameter	
Type	YX60-450
Material Width	600mm
Effective Width	450mm
Material Thickness	Steel:0.5-0.8mm

Boltless Seaming Roofing Roll Forming Machine

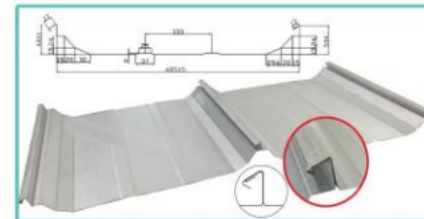

Main Technical Parameter	
Type	YX60-485
Material Width	600mm
Effective Width	485mm
Material Thickness	Steel:0.4-0.6mm

Trapezoid Rib Roofing Roll Forming Machine



Main Technical Parameter	
Type	YX32-1000
Material Width	1200mm
Effective Width	1000mm
Material Thickness	Steel:0.3-0.8mm

Rib Roofing Roll Forming Machine with Hydraulic Motor Driving



Main Technical Parameter	
Type	YX30-182.5-730
Material Width	914mm
Effective Width	730mm
Material Thickness	Steel :0.35-0.7mm

Trapezoid Rib Roofing Roll Forming Machine

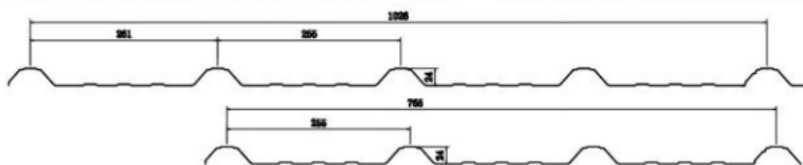

Main Technical Parameter	
Type	YX24-255-765-1026
Material Width	1219/914mm
Effective Width	1026/765mm
Material Thickness	PPGI Steel:0.3-0.6mm

Rib Roofing Machine with Laminating EPE Insulation



Main Technical Parameter	
Type	YX25-210-840
Material Width	1000mm
Effective Width	840mm
Material Thickness	EPE: 1-2mm; Steel: 0.3-0.6mm

Double Layer Rib Roofing Roll Forming Machine

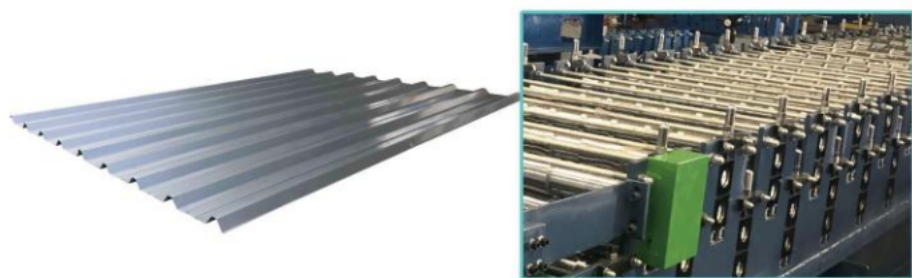

Main Technical Parameter	
Type	YX35-250-1000&YX45-250-1000
Material Width	1219mm
Effective Width	1000mm
Material Thickness	Steel:0.5-0.8mm

Double Layer Roofing Roll Forming Machine

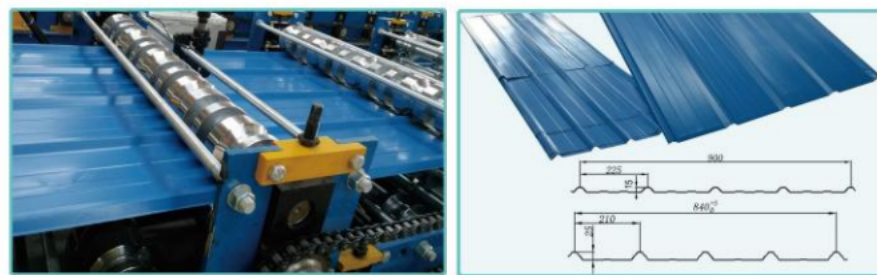
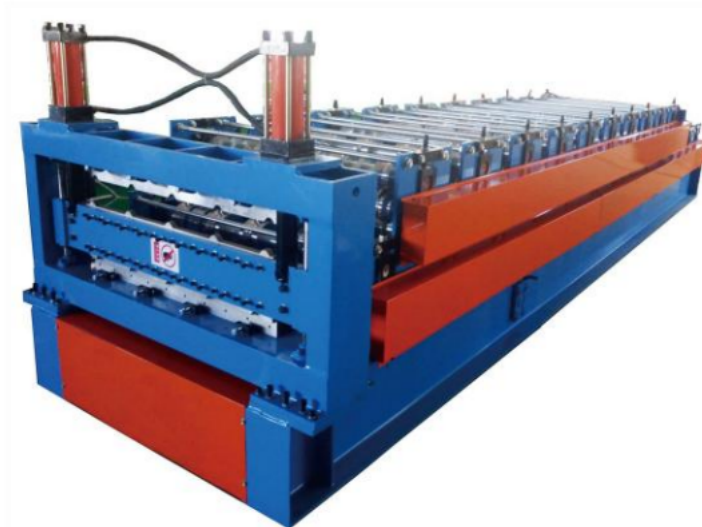

Main Technical Parameter	
Type	YX25-840/YX15-900
Material Width	1000mm
Effective Width	840mm/900mm
Material Thickness	Steel:0.3-0.6mm

Corrugated Roofing Machine with Flying Cutting & High Speed 60m/min

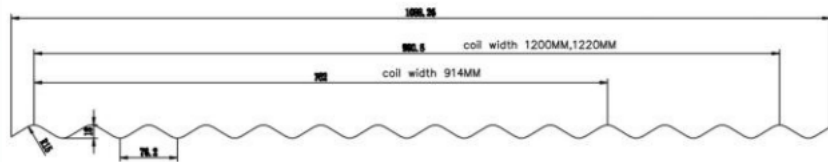

Main Technical Parameter

Type	YX18-76-762-990
Material Width	1220/914mm
Effective Width	990/762mm
Steel Thickness	0.3-0.6mm

Automatic Stacker for Roofing Panel

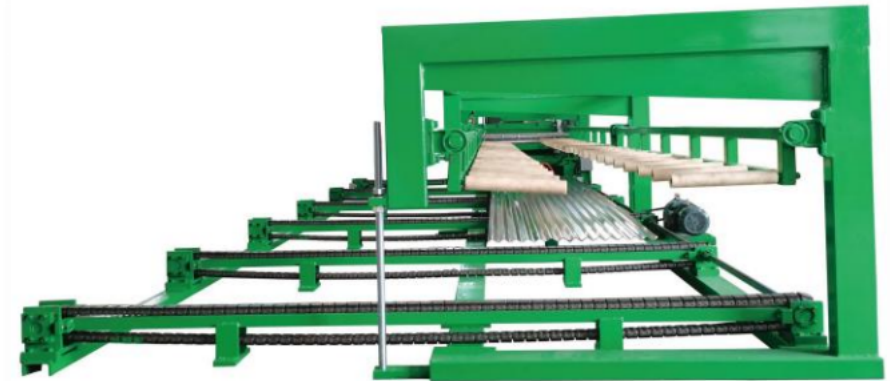

Main Technical Parameter

Type	6m, 8m, 12m
Stacking Length	6m, 8m, 12m

Shape Shearing Tile Roofing Roll Forming Machine

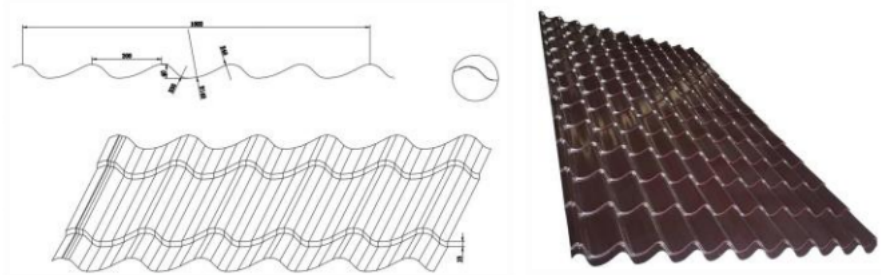
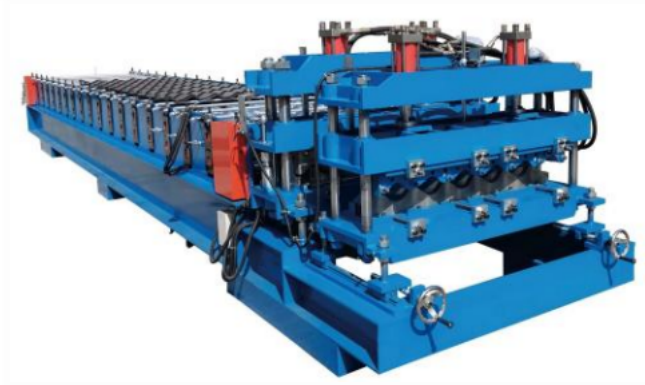

Main Technical Parameter	
Type	YX40-200-1000
Material Width	1219mm
Effective Width	1000mm
Material Thickness	PPGI Steel:0.4-0.6mm

Antique Glaed Tile Roof Roll Forming Machine

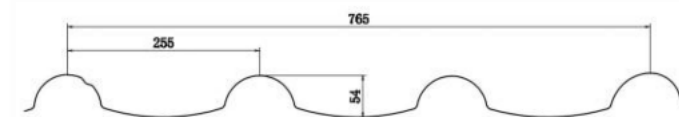

Main Technical Parameter	
Type	YX54-255-765
Material Width	1000mm
Effective Width	765mm
Material Thickness	Steel:0.3-0.6mm、Al:0.7-1.0mm

Step Tile Roofing Machine with Automatic Adjusted Thickness Gap



Main Technical Parameter	
Type	YX38.5-1005
Feeding Material Width	1220mm
Effective Cover Width	1005mm
Thickness for Steel	0.30-0.60mm

Locking Lapping Roofing Roll Forming Machine

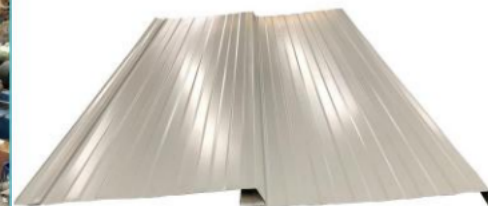

Main Technical Parameter	
Type	YX25-300
Material Width	407mm
Effective Width	300mm
Thickness for Steel	0.4-0.6mm

Ridge Cap Roll Forming Machine

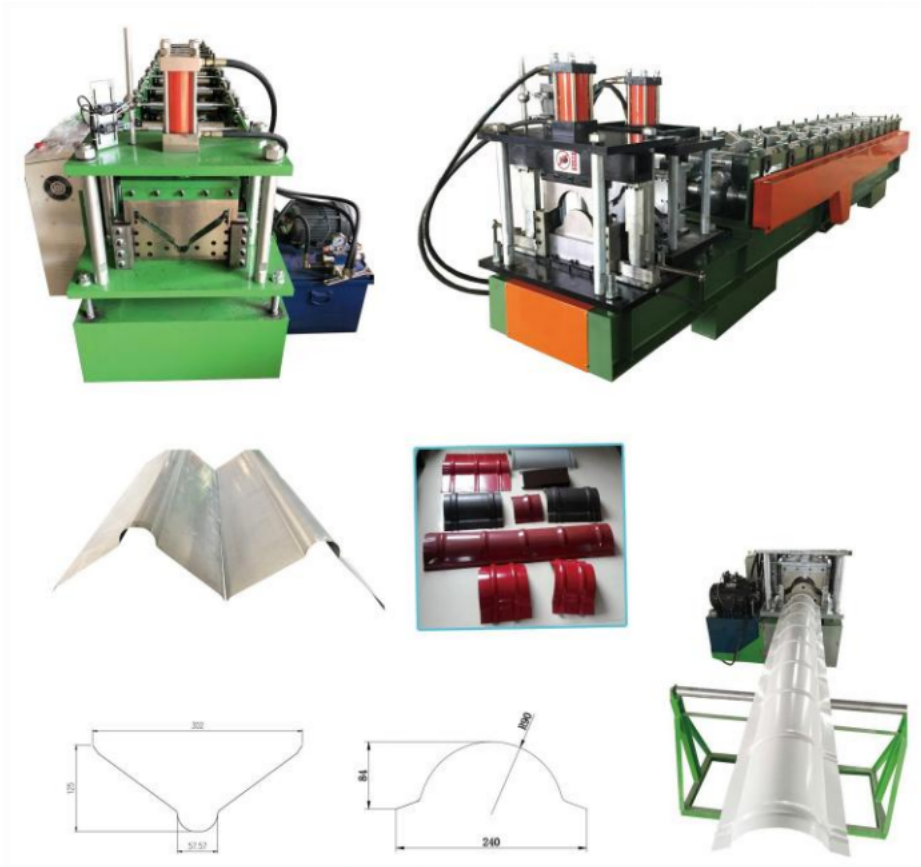

Main Technical Parameter	
Type	YX125-302
Material Width	400mm
Effective Width	302mm
Material Thickness	Steel:0.3-0.6mm

Eave Gutter Roll Forming Machine with Automatic Changed Sizes

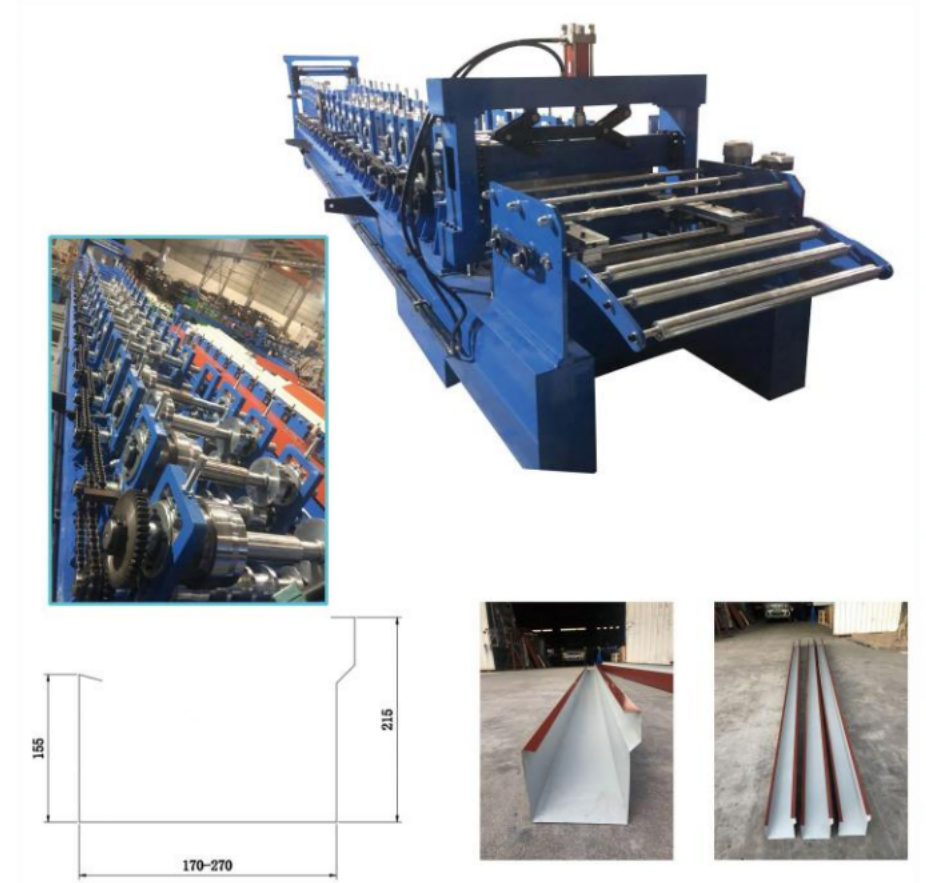

Main Technical Parameter	
Type	YX215×170-270
Material Width	590-690mm
Effective Width	Various 170-270mm
Material Thickness	0.4-0.8mm

Siding/Cladding Panel Roll Forming Machine

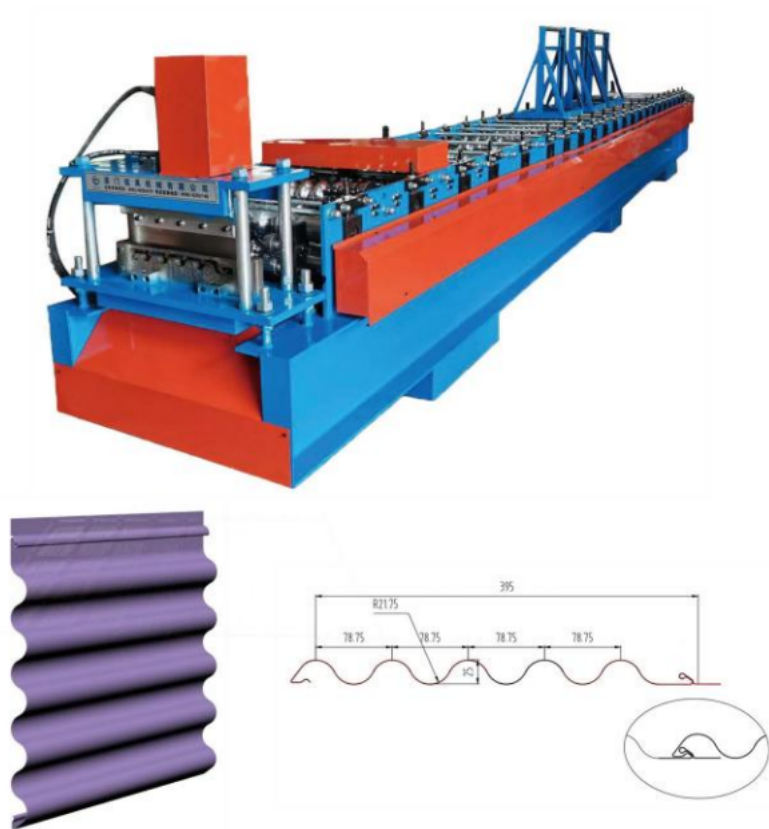

Main Technical Parameter	
Type	YX25-78.75-395
Material Width	600mm
Effective Width	395mm
Steel Thickness	0.5-0.8mm

Cladding/Wall Panel Roll Forming Machine



Main Technical Parameter	
Type	YX23-90-666
Material Width	914mm
Effective Width	666mm
Material Thickness	Steel:0.3-0.6mm

Metal Ceiling Forming Machine with Automatic Changed Size

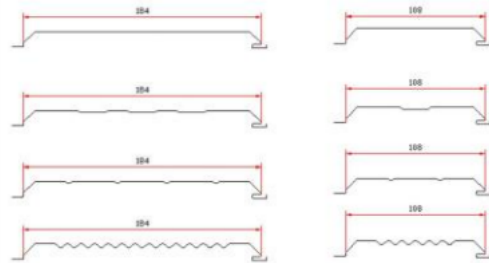

Main Technical Parameter	
Type	YX13-108-184
Material Width	152/229mm
Effective Width	108/184mm
Material Thickness	Steel:0.3-0.6mm

Fascia Board Roll Forming Machine

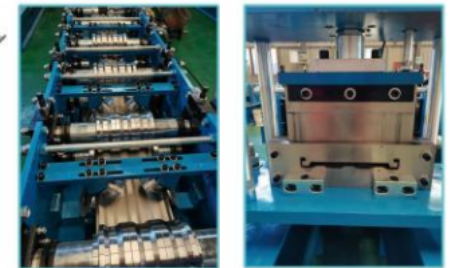

Main Technical Parameter	
Type	YX20-225
Material Width	303mm
Effective Width	225mm
Material Thickness	PPGI Steel:0.4-0.6mm

Continuous PU/PIR Roofing Sandwich Foaming Line



Main Technical Parameter	
Type	YX25,50-32×1000
Material Width	1219mm
Effective Width	1000mm
PU/PIR Thickness	20-50mm

Sandwich Bottom Panel Roll Forming Machine

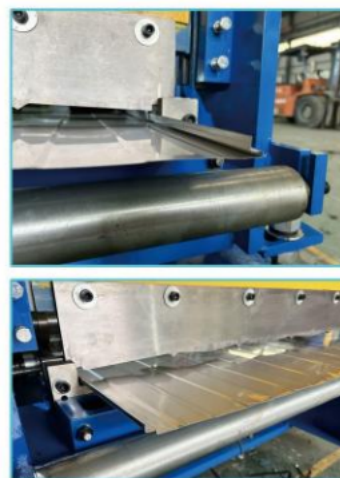

Main Technical Parameter	
Type	YX15-1170
Material Width	1219mm
Effective Width	1170mm
Steel Thickness	0.3-0.6mm

M Profile Bottom Board Roll Forming Machine

Structural Liner Tray Roll Forming Machine

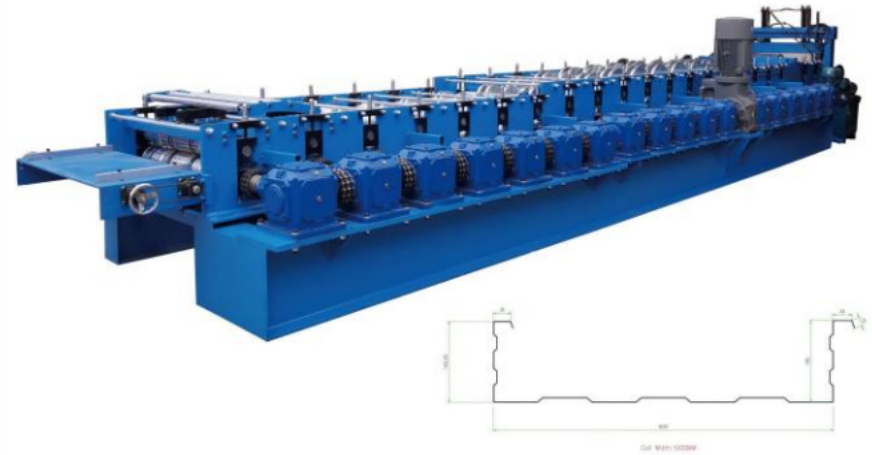
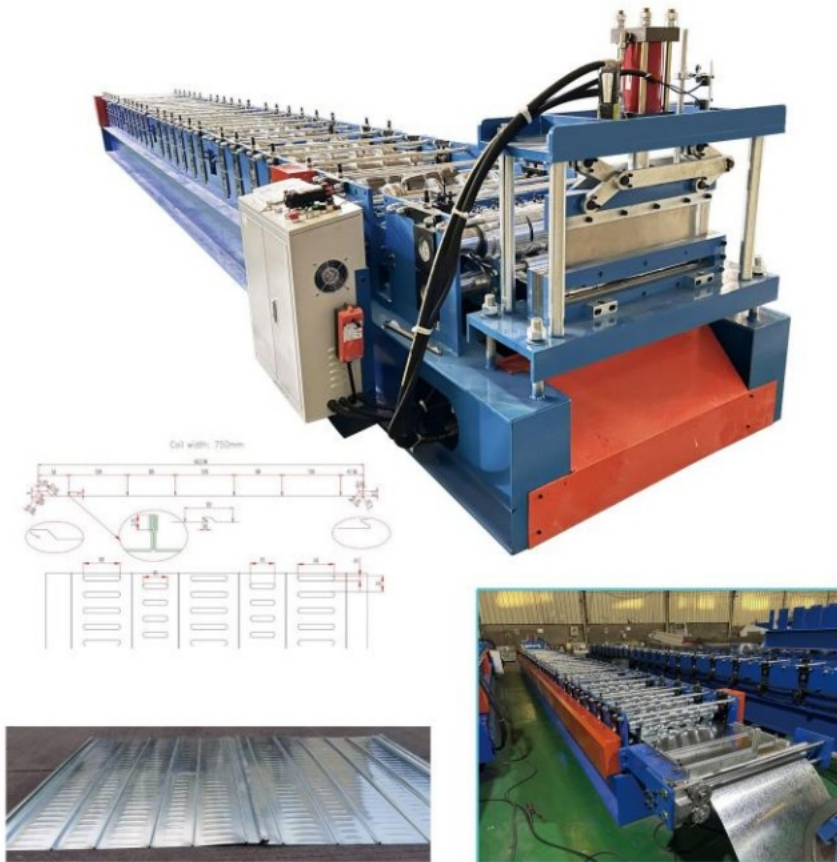

Main Technical Parameter	
Type	YX9-603
Material Width	750mm
Effective Width	603mm
Thickness	0.4-0.5mm

Main Technical Parameter	
Type	YX145-600
Material Width	1000mm
Effective Cover Width	600mm
Thickness for Steel	0.75-1.5mm

Flat Decking Forming Machine with Automatic Changed Sizes

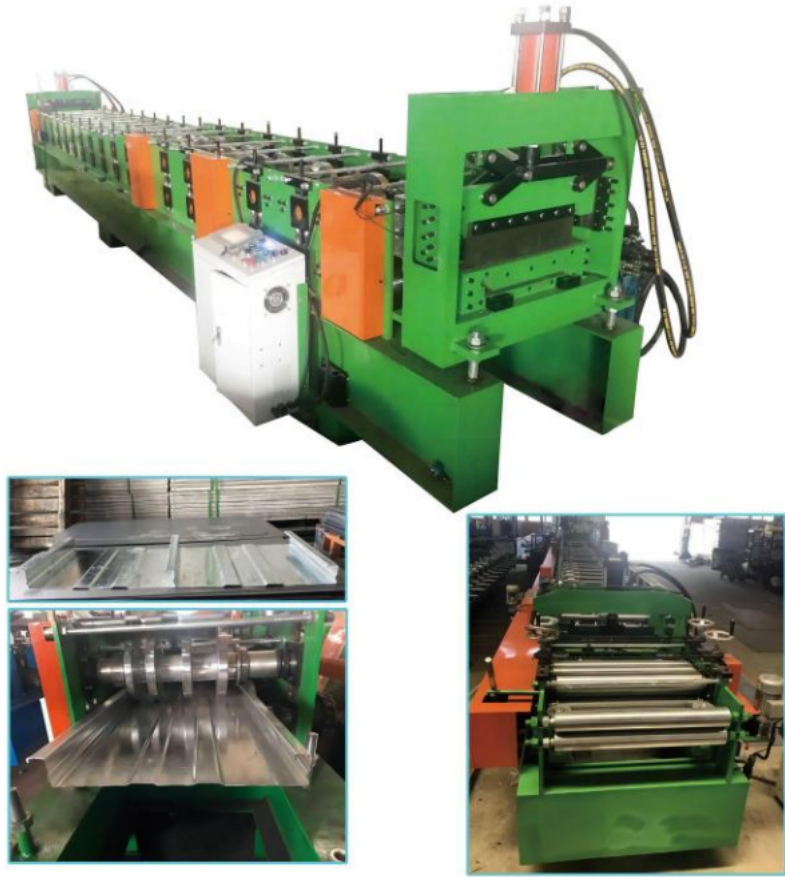

Main Technical Parameter	
Type	YX50-261-465
Material Width	407mm, 610mm
Effective Width	261mm, 460mm
Thickness for Steel	0.7-1.5mm

Web Metal Floor Decking Roll Forming Machine

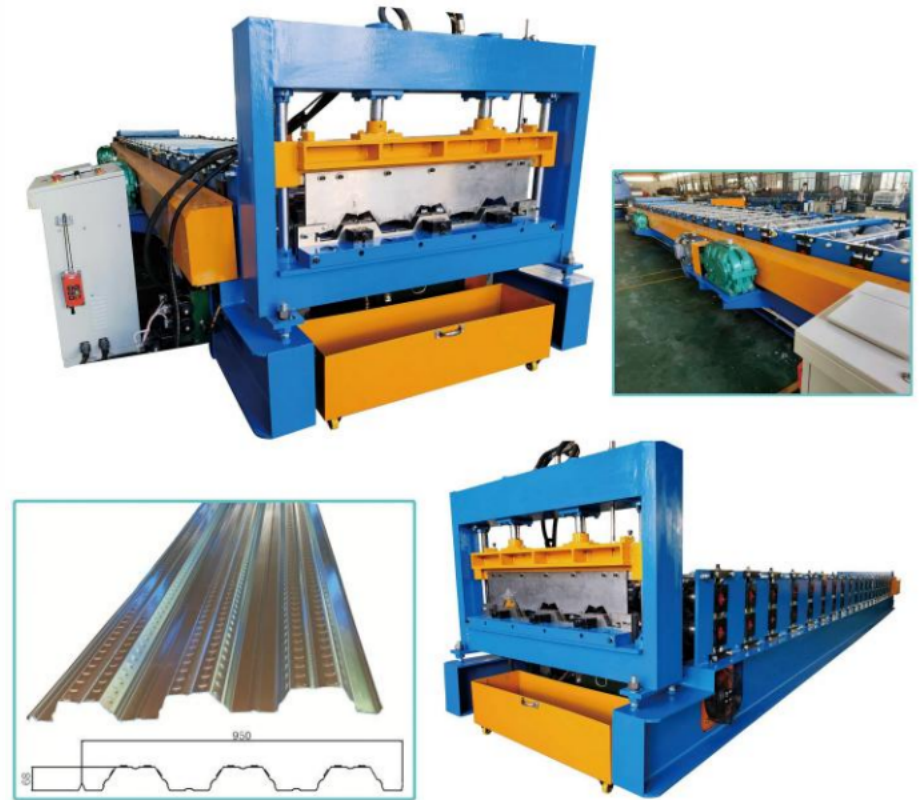

Main Technical Parameter	
Type	YX50-1000
Material Width	1219mm
Effective Width	1000mm
Material Thickness	0.8-1.6mm

Downspout Forming Machine with Curving & Decreasing 3 in 1



Main Technical Parameter	
Type	YX79-101
Material width	350mm
Effective width	101mm
Steel Thickness	0.37-0.6mm

Downpipe Forming Machine with Curving & Decreasing 3 in 1

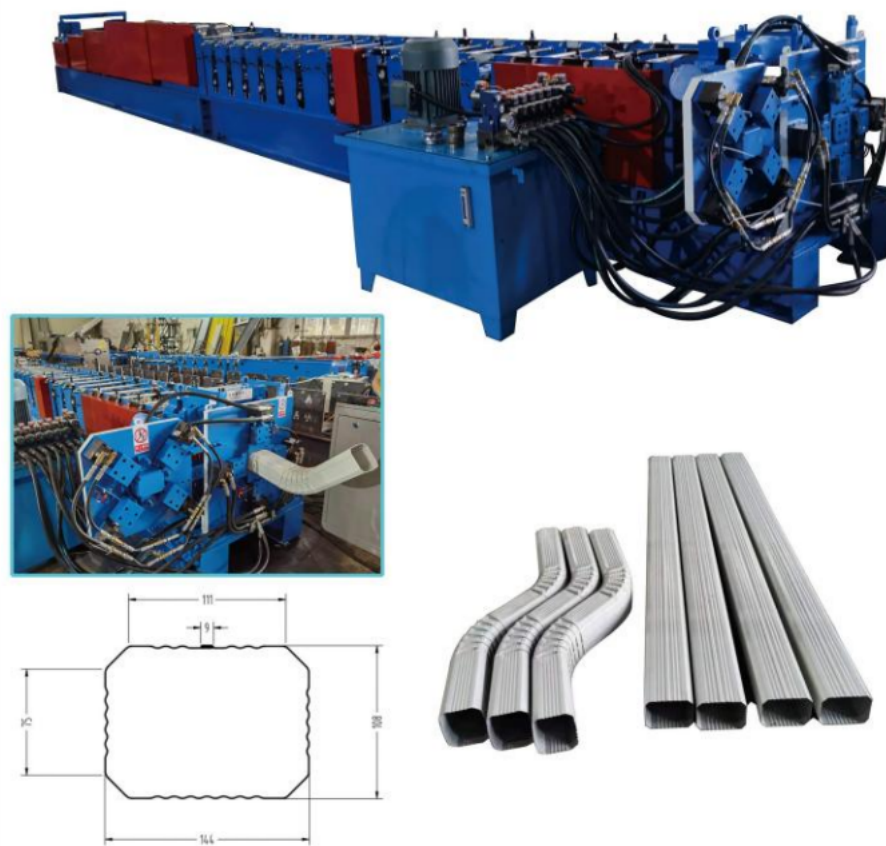

Main Technical Parameter	
Type	YX108-144
Material width	485mm
Effective width	144mm
Steel Thickness	0.4-0.6mm

Square Pipe Roll Forming Machine



Main Technical Parameter	
Type	YX75-80
Material Width	333mm
Effective Width	75X78mm
Material Thickness	0.8mm

Hat Shape Purlin Forming Machine with Automatic Changed Sizes



Main Technical Parameter	
Type	H30-125x50-200
Material Width	130/520mm
Effective Width	50/200mm
Material Thickness	1.0-3.0mm

Unistruct/C Channel Roll Forming Machine For SS316



Main Technical Parameter	
Type	YX41-41
Material Width	135mm
Effective Width	41mm
Steel Thickness	SS, Mild Steel: 2.0-2.5mm

Automatic Adjusted C/U Profile Machine with Flying Cutting & High Speed 60m/min



Main Technical Parameter	
Type	CU50-102
Material Width	122-200mm
Effective Width	50-102mm
Steel Thickness	0.4-0.8mm

C Purlin Roll Forming Machine with Automatic Changed Sizes

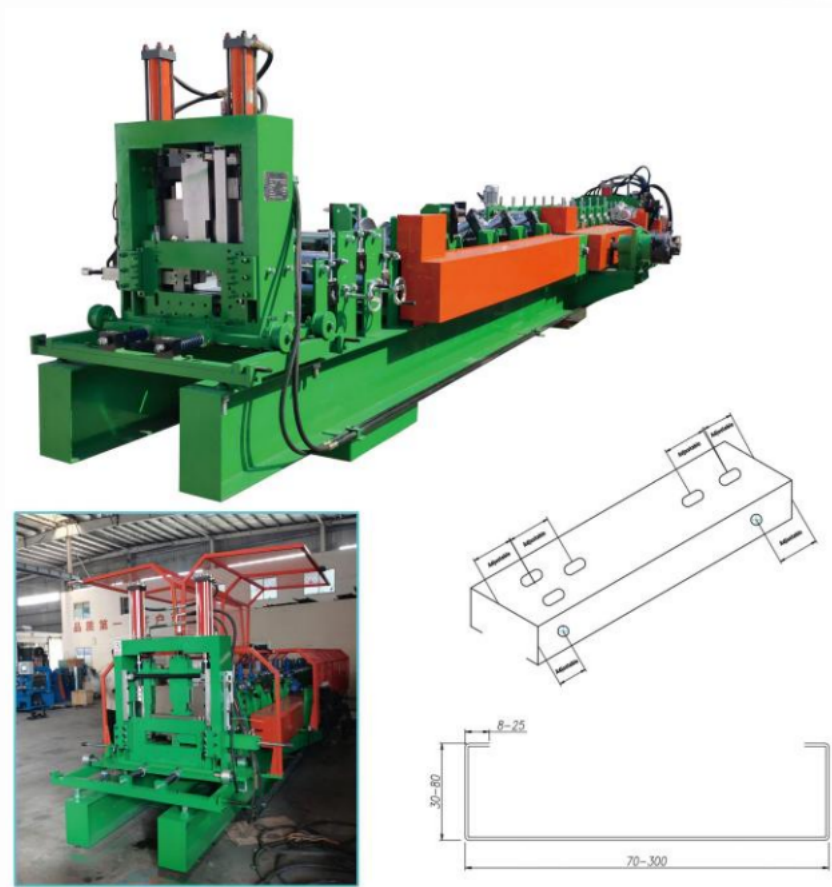

Main Technical Parameter	
Type	C70-300
Web Width	70-300mm
Flange Size	30-80mm
Material Thickness	1.0-3.0mm

Z Automatic Adjusted Purlin Roll Forming Machine



Main Technical Parameter	
Type	Z140-300
Web Width	140-300mm
Flange Size	50-100mm
Material Thickness	1.5-3.0mm

Automatic C & Z Interchangeable Purlin Machine



Main Technical Parameter	
Type	C,Z100-300
Web Width	100-300mm
Flange Size	30-70mm
Material Thickness	1.0-3.0mm

Automatic Stacker for C Purlin Machine



Main Technical Parameter	
Type	6M
Stacking Length	5m, 6m

Uncoiler



Seaming Machine





Roofing Brackets



Steel Roofing Clamp



Al Roofing Clamp



475 Sliding Clip



1 1/2" SS Fixed/ Sliding Clips



75/470 Sliding Clips



Steel Clips for 65 standing seam



Ø16mm, 19mm
Ø22mm, 25mm

Shear Studs for Decking



1.5" Steel Sliding Clips



Steel Clamp Brackets



Al Clips for 65 standing seam

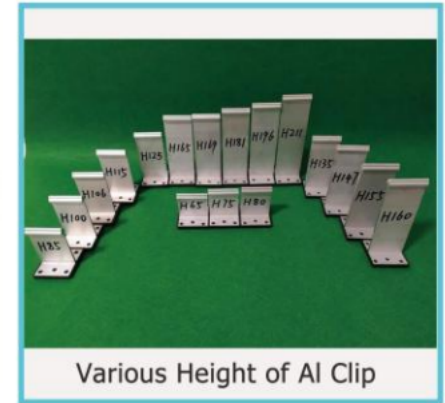

Various Height of Al Clip